

DH071/DR071

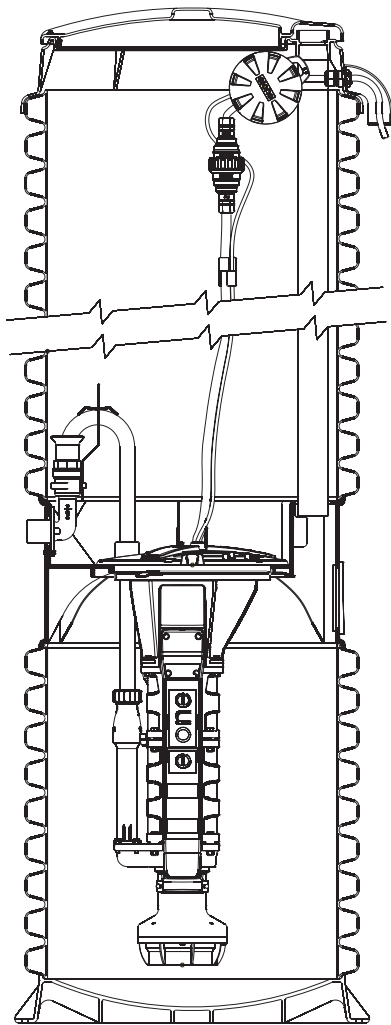

General Features

The model DH071 or DR071 grinder pump station is a complete unit that includes: the grinder pump, check valve, HDPE (high density polyethylene) tank and controls. The DH071 or DR071 is packaged into a single complete unit, ready for installation.

The DH071 is the “hardwired,” or “wired,” model where a cable connects the motor controls to the level controls through watertight penetrations.

The DR071 is the “radio frequency identification” (RFID), or “wireless,” model that uses wireless technology to communicate between the level controls and the motor controls.

All solids are ground into fine particles, allowing them to pass easily through the pump, check valve and small diameter pipelines. Even objects not normally found in sewage, such as plastic, rubber, fiber, wood, etc., are ground into fine particles.

The 1.25-inch discharge connection is adaptable to any piping materials, thereby allowing us to meet your local code requirements.

The tank is made of tough corrosion-resistant HDPE. The optimum tank capacity of 70 gallons is based on computer studies of water usage patterns. A single DH071 or DR071 is ideal for one, average single-family home and can also be used for up to two average single-family homes where codes allow and with consent of the factory. This model can accommodate flows of 700 GPD.

The internal check valve assembly, located in the grinder pump, is custom-designed for non-clog, trouble-free operation.

The grinder pump is automatically activated and runs infrequently for very short periods. The annual energy consumption is typically that of a 40-watt light bulb.

Units are available for indoor and outdoor installations. Outdoor units are designed to accommodate a wide range of burial depths.

Operational Information

Motor

1 hp, 1,725 rpm, high torque, capacitor start, thermally protected, 120/240V, 60 Hz, 1 phase

Inlet Connections

4-inch inlet grommet standard for DWV pipe. Other inlet configurations available from the factory.

Discharge Connections

Pump discharge terminates in 1.25-inch NPT female thread. Can easily be adapted to 1.25-inch PVC pipe or any other material required by local codes.

*Discharge**

15 gpm at 0 psig

11 gpm at 40 psig

7.8 gpm at 80 psig

Overload Capacity

The maximum pressure that the pump can generate is limited by the motor characteristics. The motor generates a pressure well below the rating of the piping and appurtenances. The automatic reset feature does not require manual operation following overload.

Patent Numbers: 5,752,315
5,562,254 5,439,180

* Discharge data includes loss through check valve, which is minimal.

NA0050P01

OPTIONS : **DH071** (HARD WIRED LEVEL CONTROLS)
 DR071 (WIRELESS LEVEL CONTROLS)

FIELD JOINT REQUIRED
 FOR MODELS
 DH071-129 / DR071-129
 &
 DH071-160 / DR071-160

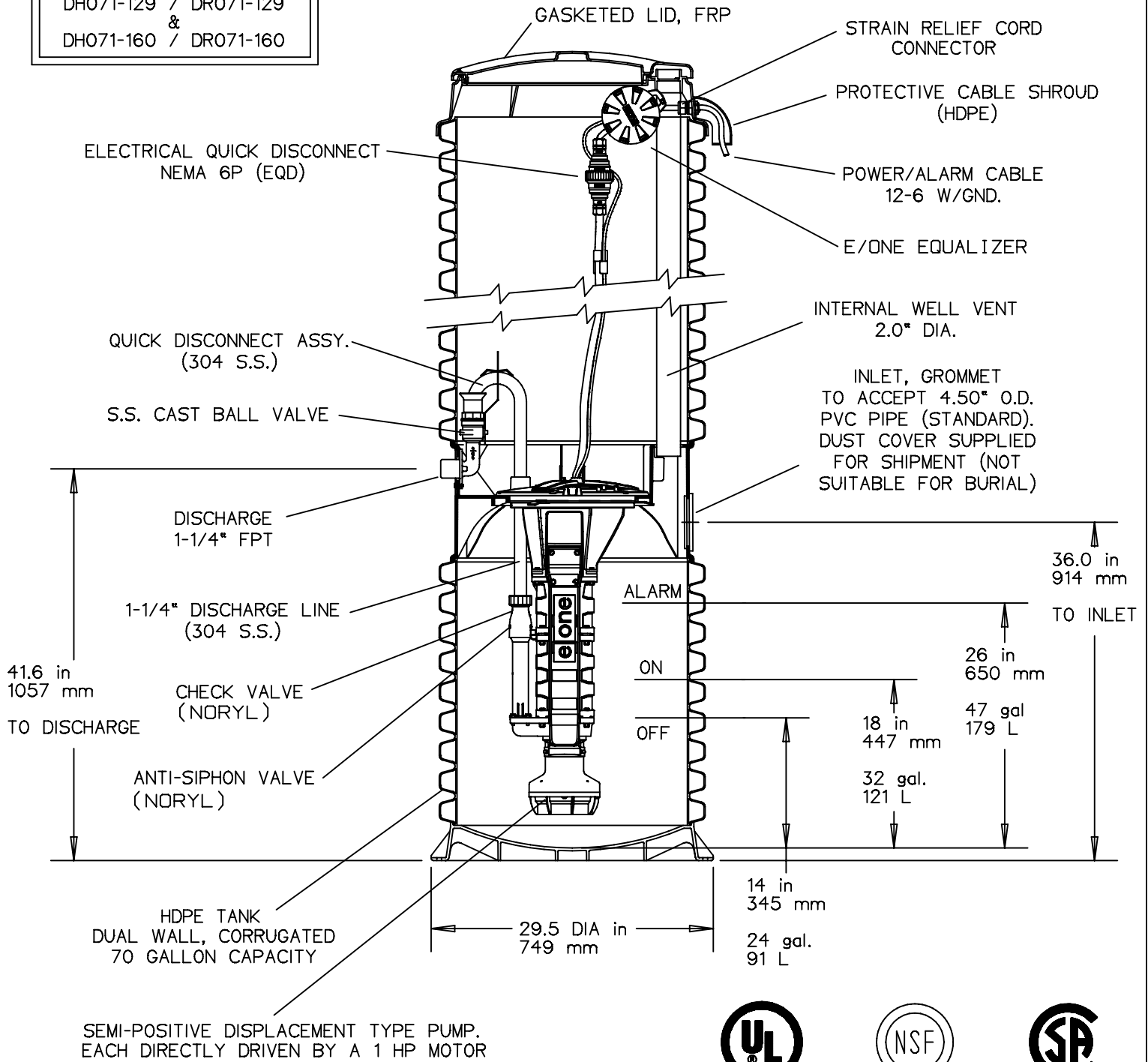

CONCRETE BALLAST MAY BE REQUIRED
 SEE INSTALLATION INSTRUCTIONS
 FOR DETAILS



AD	CH	07/12/07	A	
DR BY	CHK'D	DATE	ISSUE	SCALE



MODEL DH071 / DR071
 DETAIL SHEET

NA0050P02

DH071-44

INDOOR UNIT

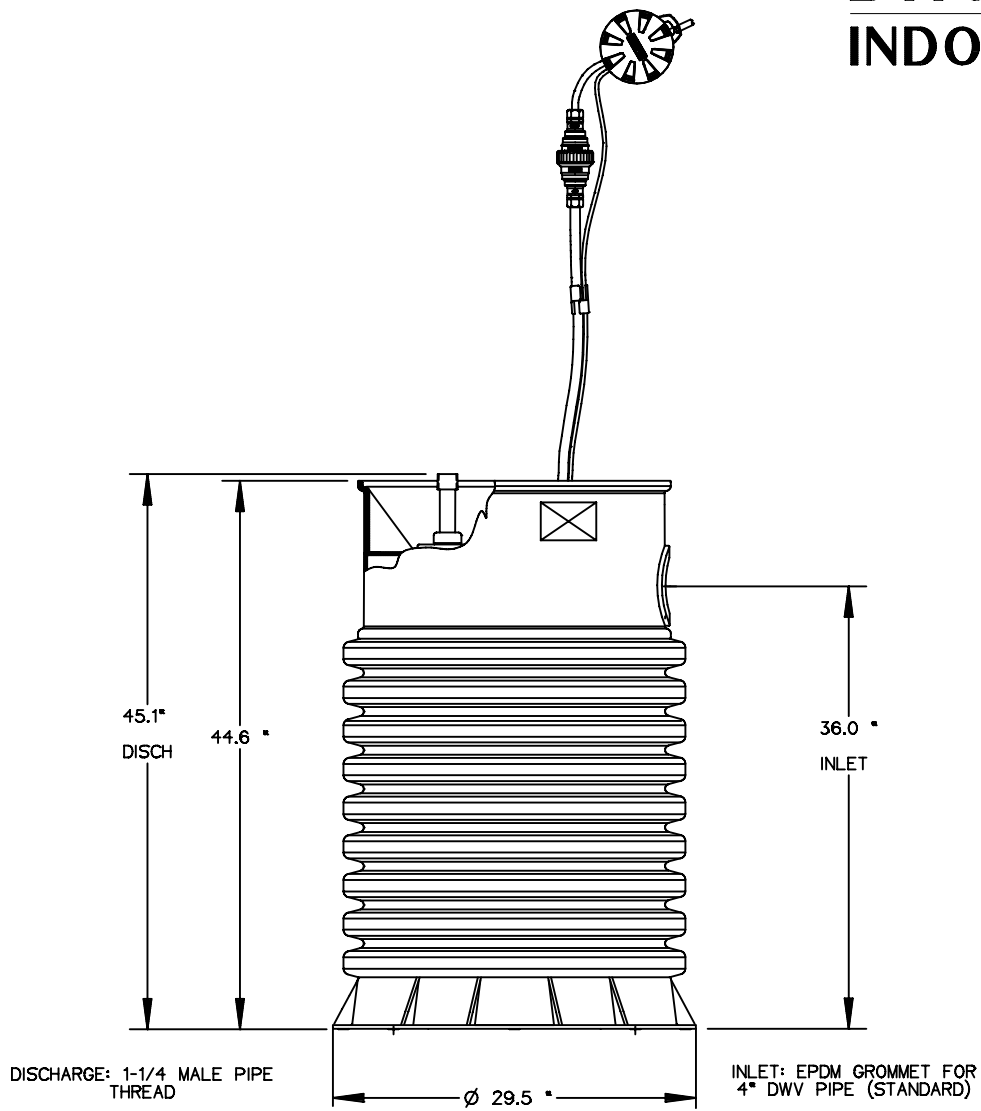

LNT	GAE	04/24/07	-	
DR BY	CHK'D	DATE	ISSUE	SCALE



MODEL DH071-44

NA0050P03

OPTIONS : **DH071-61** (HARD WIRED LEVEL CONTROLS)
 DR071-61 (WIRELESS LEVEL CONTROLS)

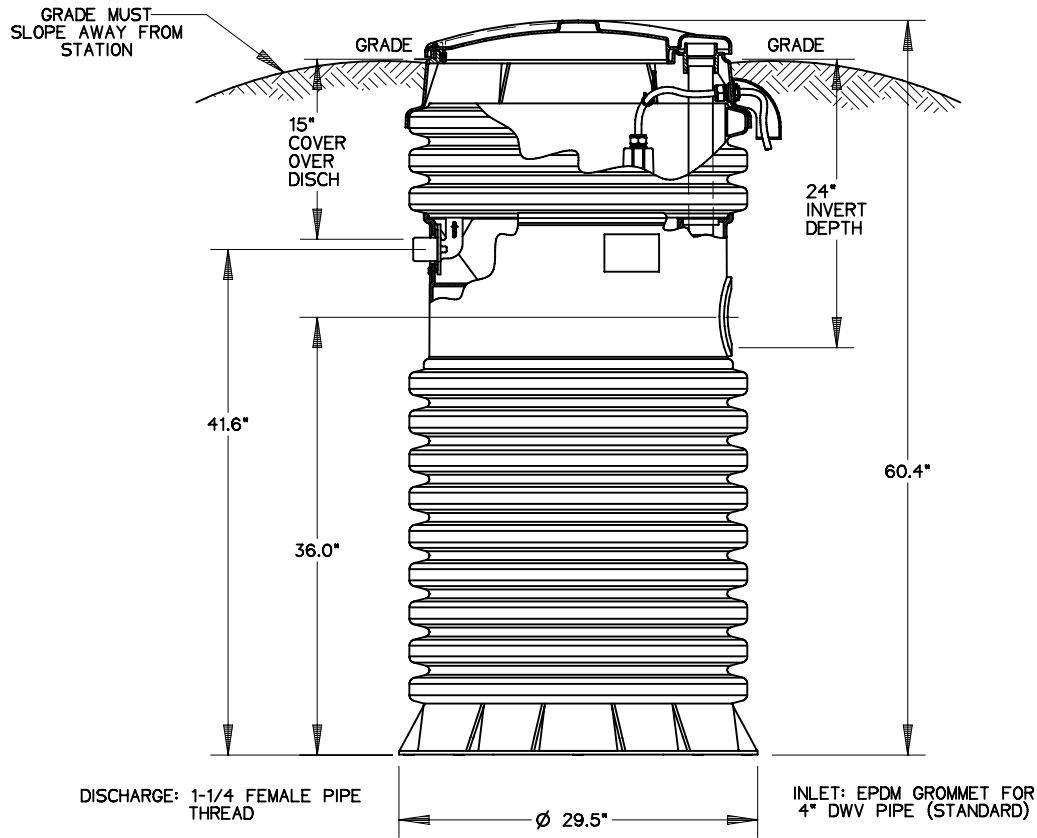

CONCRETE BALLAST MAY BE REQUIRED
 SEE INSTALLATION INSTRUCTIONS
 FOR DETAILS



AD	CAH	07/12/07	A	1/16
DR BY	CHK'D	DATE	ISSUE	SCALE



MODEL DH071-61 / DR071-61

NA0050P04

OPTIONS : **DH071-74**
 DR071-74

(HARD WIRED
LEVEL CONTROLS)

(WIRELESS
LEVEL CONTROLS)

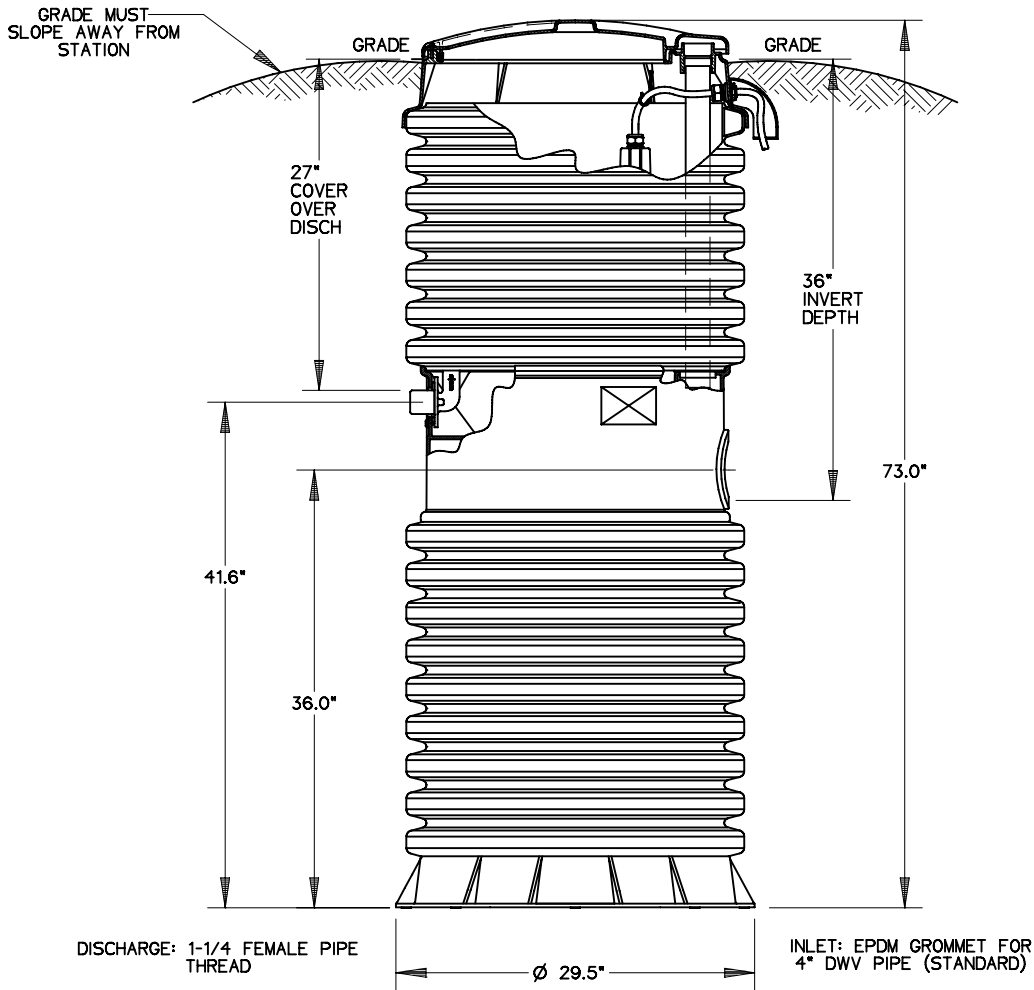

CONCRETE BALLAST MAY BE REQUIRED
SEE INSTALLATION INSTRUCTION
FOR DETAILS



AD	CAH	07/12/07	A	1/16
DR BY	CHK'D	DATE	ISSUE	SCALE



MODEL DH071-74 / DR071-74

NA0050P05

OPTIONS : **DH071-93**

(HARD WIRED
LEVEL CONTROLS)

DR071-93

(WIRELESS
LEVEL CONTROLS)

GRADE MUST SLOPE
AWAY FROM STATION

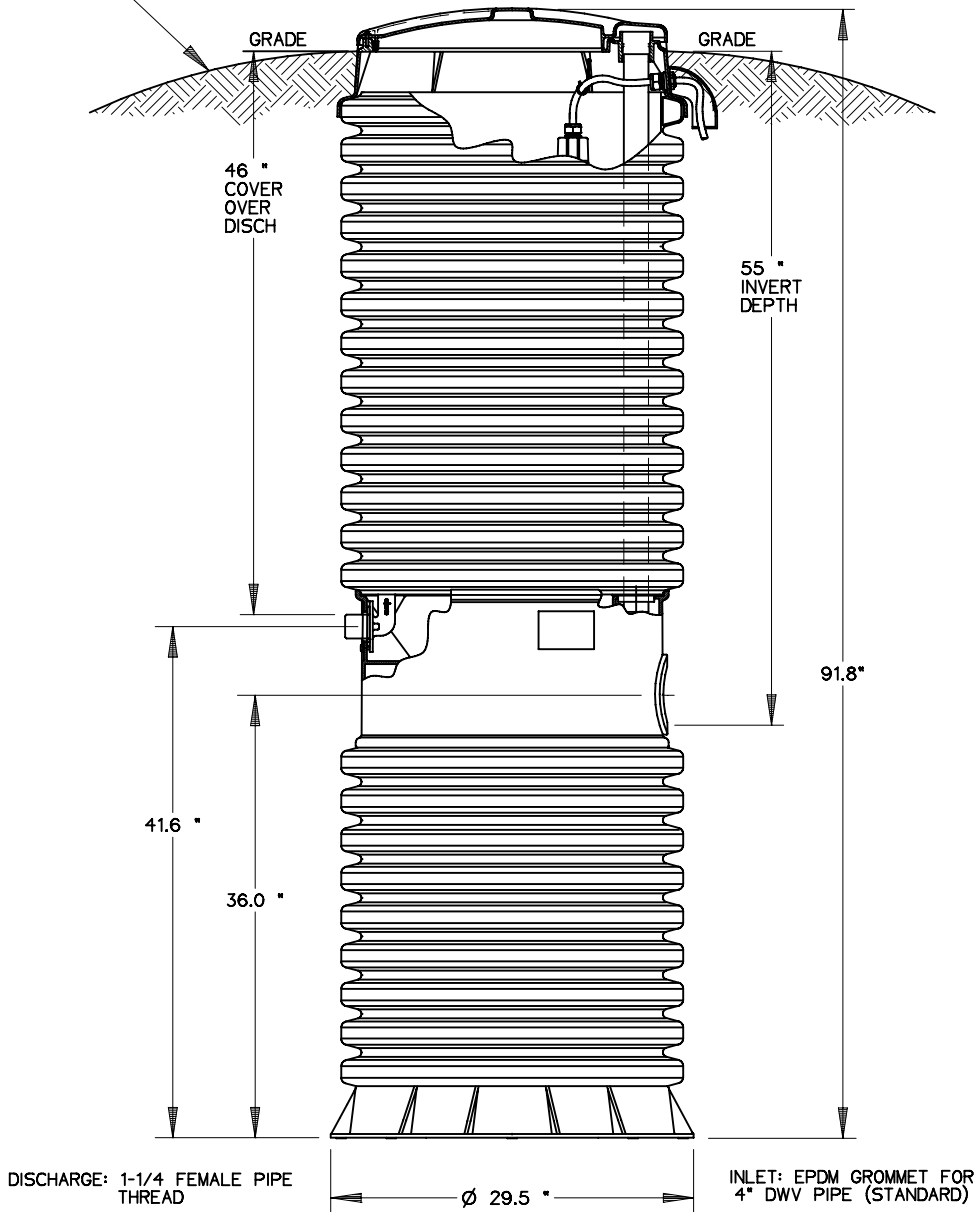

CONCRETE BALLAST MAY BE REQUIRED
SEE INSTALLATION INSTRUCTIONS
FOR DETAILS



AD	CAH	07/12/07	A	1/16
DR BY	CHK'D	DATE	ISSUE	SCALE
 SEWER SYSTEMS				
MODEL DH071-93 / DR071-93				
NA0050P06				

OPTIONS : **DH071-124**

(HARD WIRED
LEVEL CONTROLS)

DR071-124

(WIRELESS
LEVEL CONTROLS)

GRADE MUST SLOPE
AWAY FROM STATION

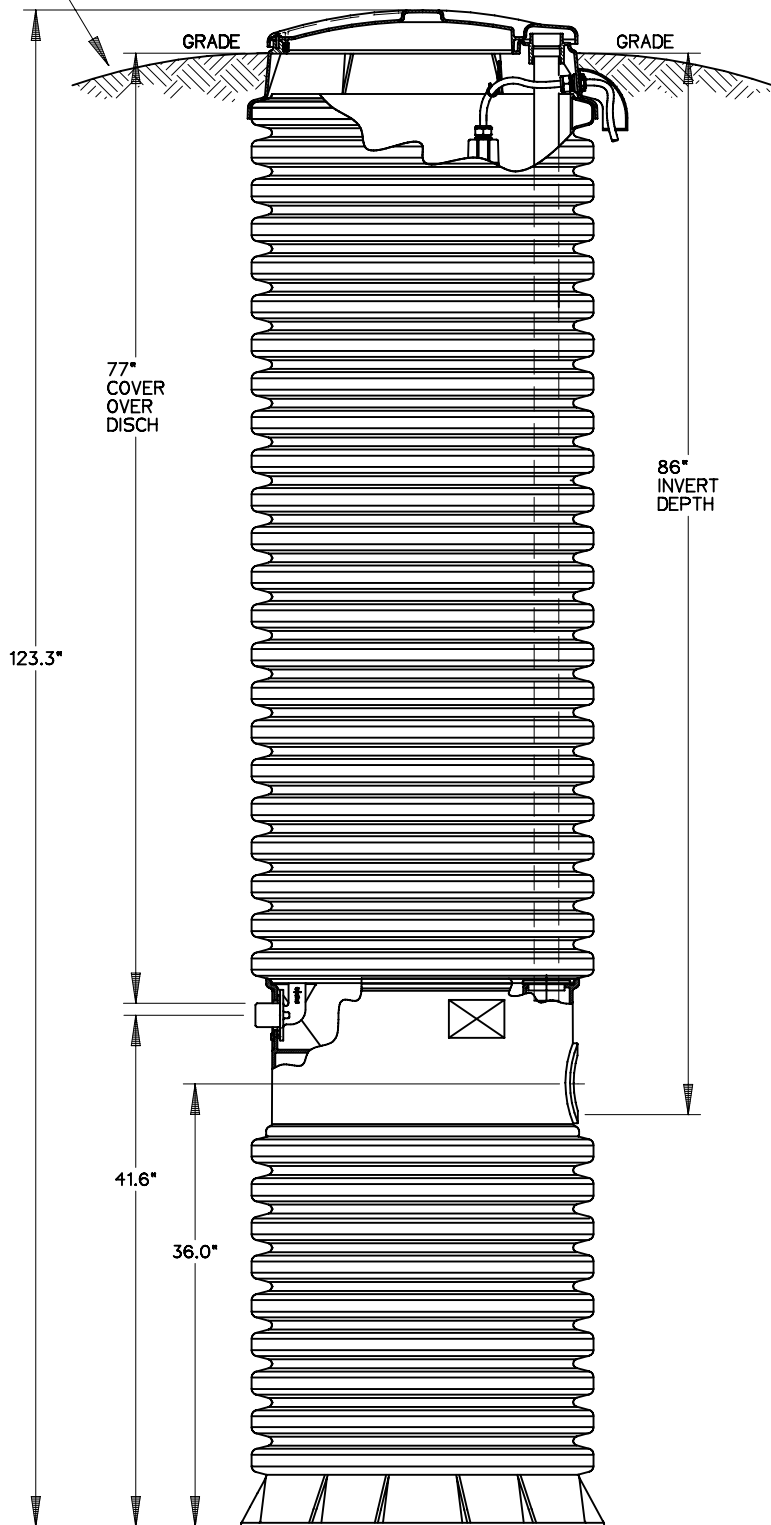

77"
COVER
OVER
DISCH

86"
INVERT
DEPTH

123.3"

41.6"

36.0"

DISCHARGE:
1-1/4 FEMALE
PIPE THREAD

Ø 29.5"

INLET:
EPDM GROMMET
FOR 4" DWV
PIPE (STANDARD)

CONCRETE BALLAST MAY BE REQUIRED
SEE INSTALLATION INSTRUCTIONS
FOR DETAILS



AD	CAH	07/13/07	A	1/16
DR BY	CHK'D	DATE	ISSUE	SCALE



MODEL DH071-124 / DR071-124

NA0050P07

OPTIONS : **DH071-129**
 DR071-129

(HARD WIRED
LEVEL CONTROLS)

(WIRELESS
LEVEL CONTROLS)

GRADE MUST SLOPE
AWAY FROM STATION

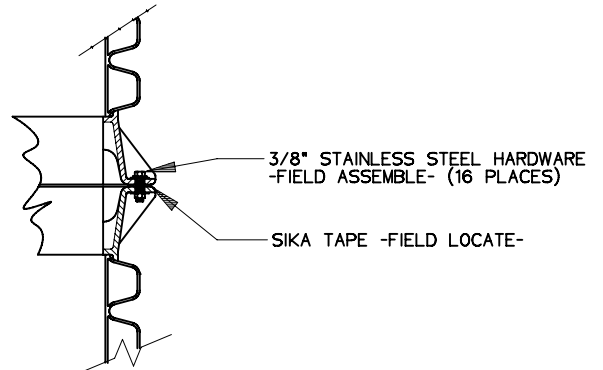
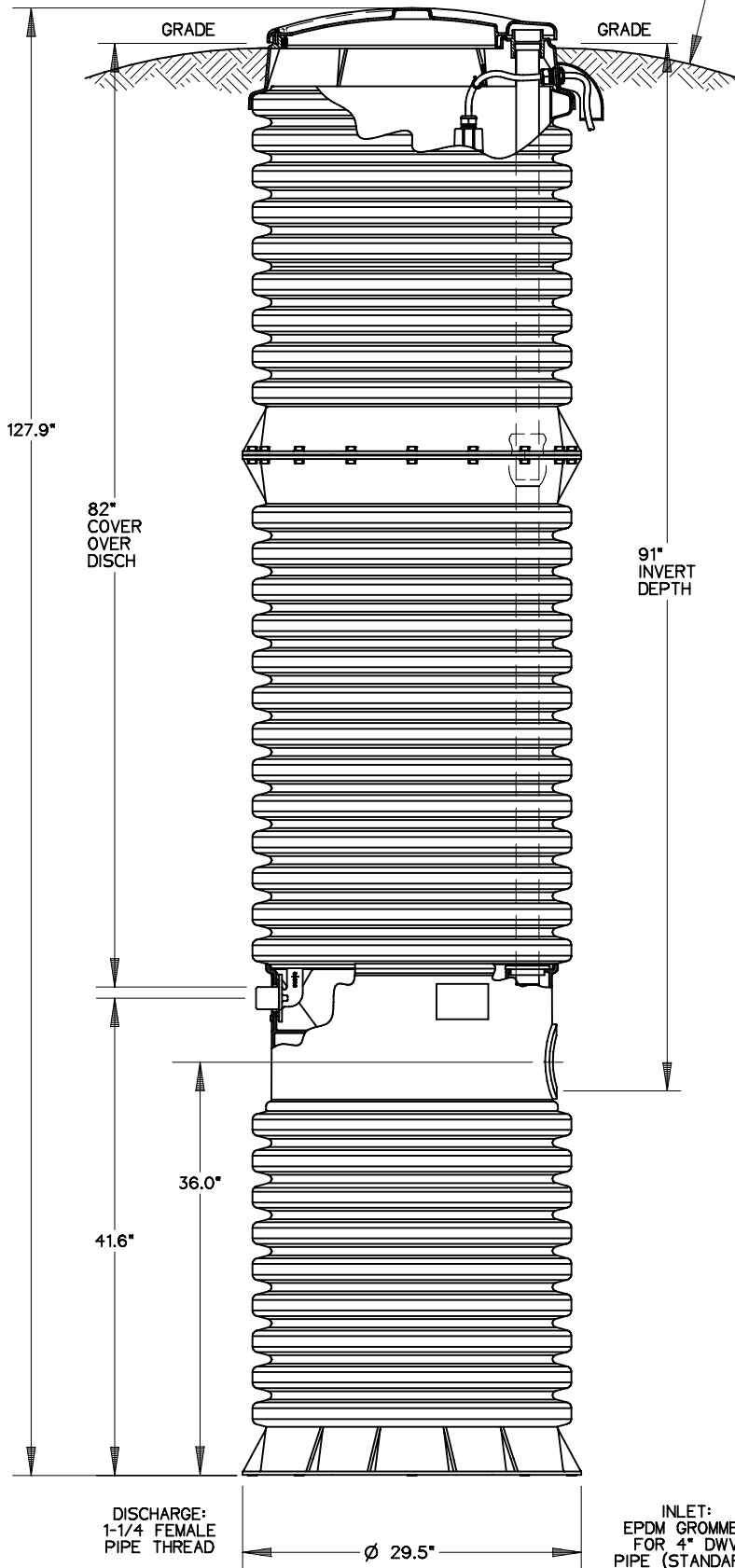

DETAIL, FIELD JOINT

SEE INSTALLATION INSTRUCTIONS
FOR FURTHER DETAILS

CONCRETE BALLAST MAY BE REQUIRED
SEE INSTALLATION INSTRUCTIONS
FOR DETAILS



AD	CAH	07/13/07	A	1/16
DR BY	CHK'D	DATE	ISSUE	SCALE



MODEL DH071-129 / DR071-129

NA0050P08

OPTIONS : **DH071-158** (HARD WIRED LEVEL CONTROLS)
 DR071-158 (WIRELESS LEVEL CONTROLS)

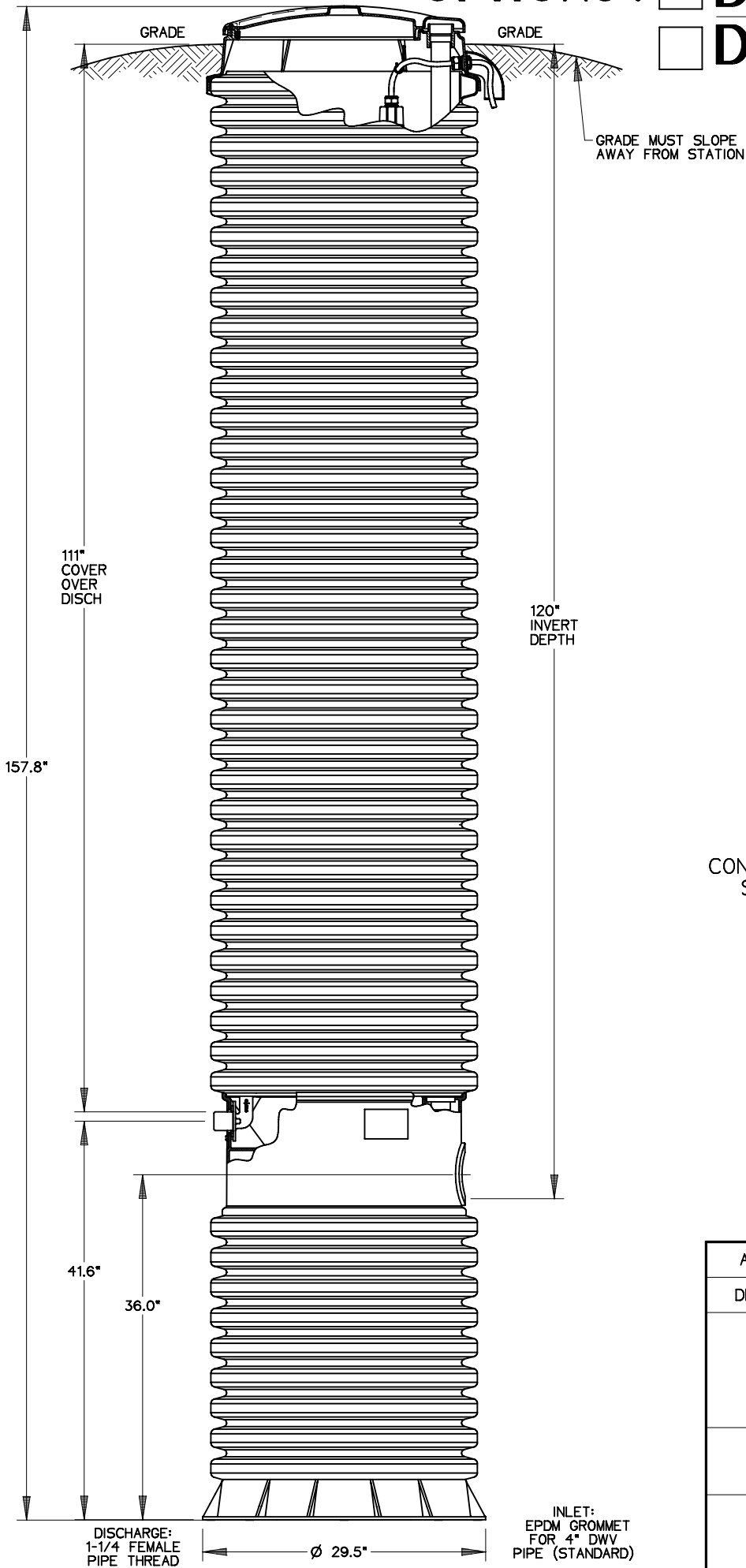

CONCRETE BALLAST MAY BE REQUIRED
 SEE INSTALLATION INSTRUCTIONS
 FOR DETAILS



AD	CAH	07/13/07	A	1/16
DR BY	CHK'D	DATE	ISSUE	SCALE



MODEL DH071-158 / DR071-158

NA0050P09

OPTIONS : **DH071-160** (HARD WIRED LEVEL CONTROLS)
 DR071-160 (WIRELESS LEVEL CONTROLS)

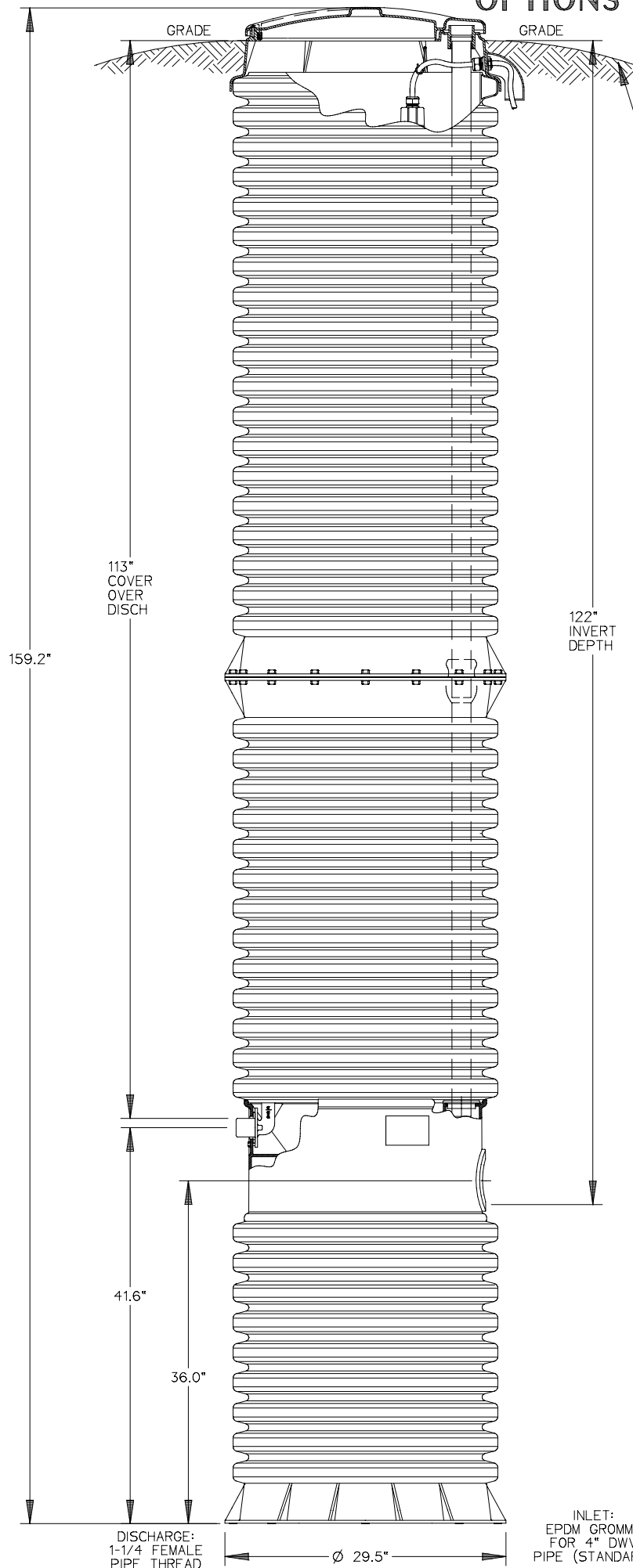

GRADE MUST SLOPE AWAY FROM STATION

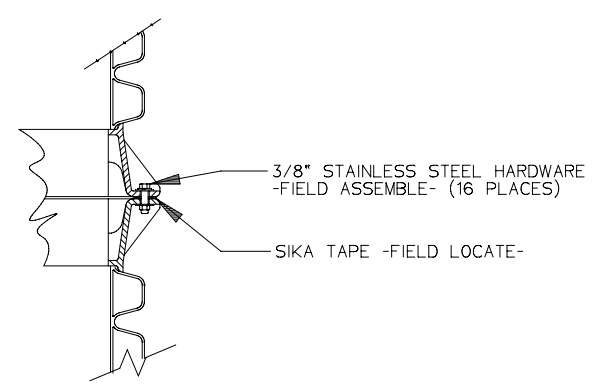

DETAIL, FIELD JOINT

SEE INSTALLATION INSTRUCTIONS FOR FURTHER DETAILS

CONCRETE BALLAST MAY BE REQUIRED SEE INSTALLATION INSTRUCTIONS FOR DETAILS





AD	CAH	07/13/07	A	1/16
DR BY	CHK'D	DATE	ISSUE	SCALE
MODEL DH071-160 / DR071-160				
NA0050P10				

DH071-57

BUILDERS MODEL

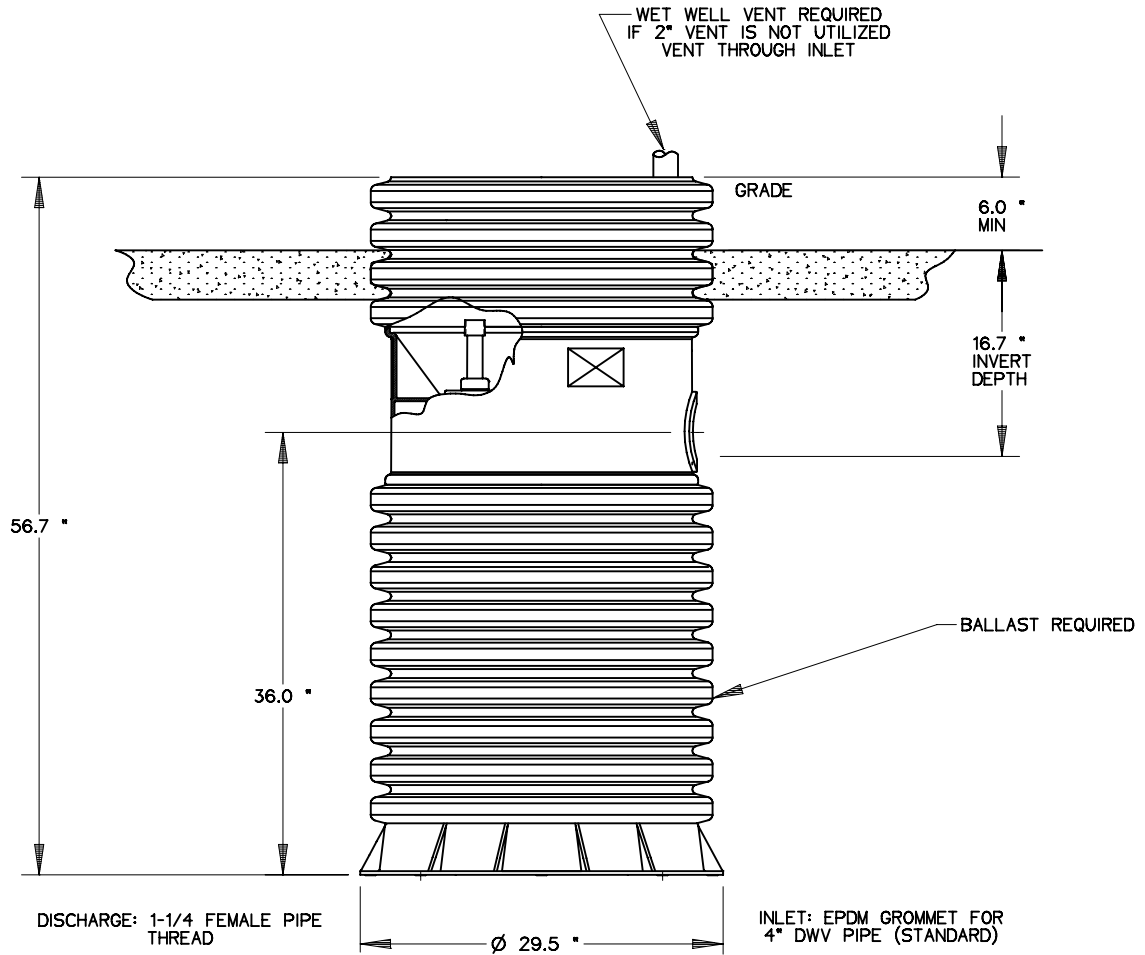
STRAIGHT DISCHARGE





AD	CAH	04/26/07	-	1/16
DR BY	CHK'D	DATE	ISSUE	SCALE
 SEWER SYSTEMS				
MODEL DH071-57 BUILDERS				
NA0050P11				

DH071-57

BUILDERS MODEL

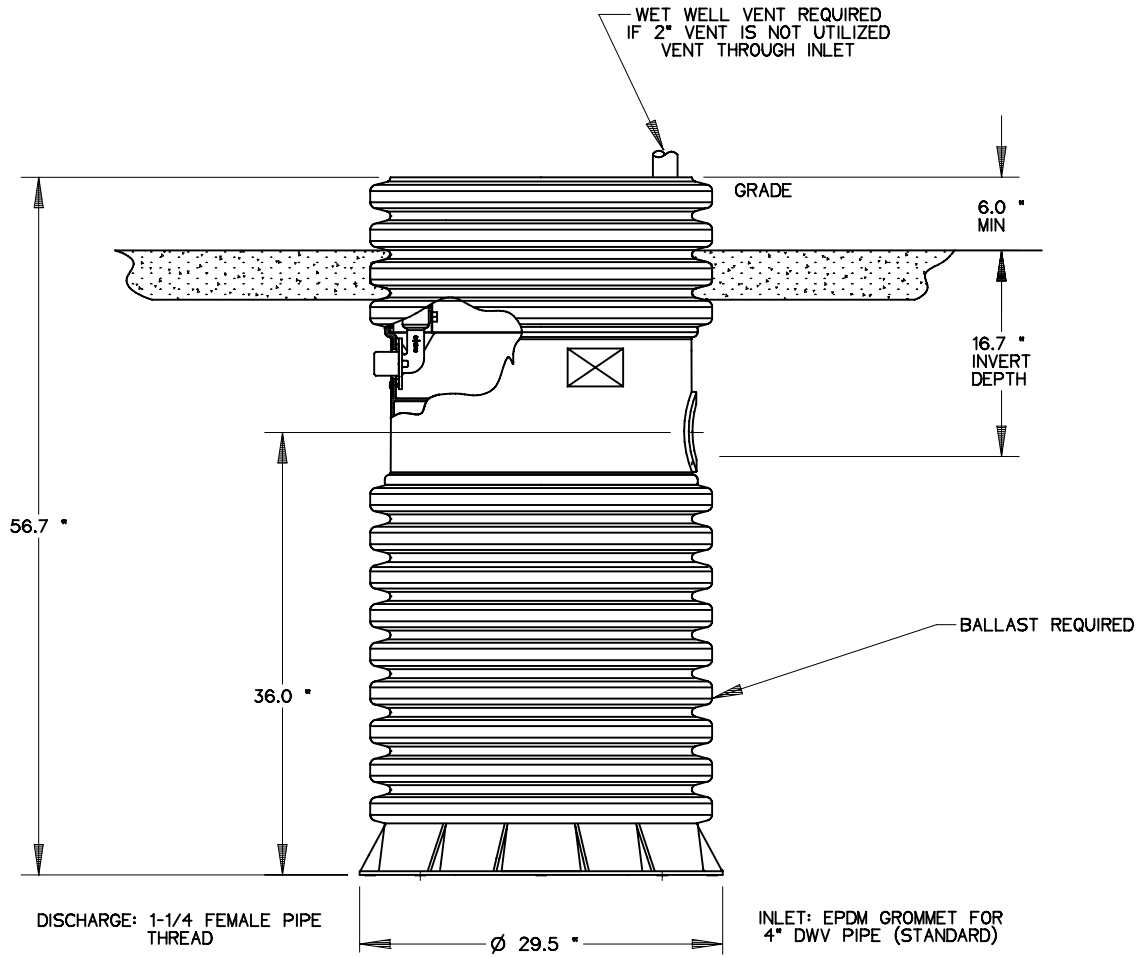
DISCHARGE VALVE



AD	CAH	04/26/07	-	1/16
DR BY	CHK'D	DATE	ISSUE	SCALE
 SEWER SYSTEMS				
MODEL DH071-57 BUILDERS				
NA0050P12				